

PRODUCT DATA SHEET

CLA INOX250A • 807725



PRODUCT DETAILS

The Claytech Self-Priming Inox Series multistage pump is well-known for its quiet and reliability in the Australian market. Designed for use in a larger home, it is more energy efficient than a jet pump and can self prime to a depth of 4 meters. This makes it ideal for above and below ground rainwater tanks.

BENEFITS

- Self priming enables the pump to draw reliably from water lower than the pump inlet
- High flow, flat consistent performance curve.
- Complies with AS/NZS 4020 requirements

FEATURES

- Multi-stage pump
- Quiet, reliable operation
- Designed for larger homes
- Self-Priming
- Automatic Operation - adjustable start pressure
- Controller includes a pressure gauge
- Inbuilt dry run protection

BRAND



TECHNICAL DATA

P1 RATED POWER (W)	985W
MAX. FLOW [LPM]	100 lpm
MAX. HEAD [M]	60m
WORKING TEMPERATURE	< 40°C
LIQUID TEMPERATURE	2°C - 35°C
MAX. WORKING PRESSURE	6 Bar
MOTOR DUTY	S1 Continuous
MOTOR PROTECTION LEVEL	Class F
PUMP BODY	Stainless Steel
PUMP INTERNALS	Composite
MOTOR PROTECTION	In-built auto re-setting thermal overload
CAPACITOR	20.0 uF +/-5% 450V

RATED VOLTAGE	220V-240V 50 Hz
RATED CURRENT	5.5A @ 230V
POWER CABLE TYPE	2m H07RN-F
PROTECTION CLASS	IPX4
INLET	1" BSPF
OUTLET	1" BSPF
MECHANICAL SEAL	Carbon/Ceramic
MOTOR SHAFT	Stainless Steel
IMPELLER MATERIAL	Composite
AUTOMATION FUNCTION	Yes, with adjustable start pressure
NET WEIGHT (KG)	14.5 kg
PACKAGE DIMENSION	590Lx280Wx300H (mm)

HYDRAULIC PERFORMANCE

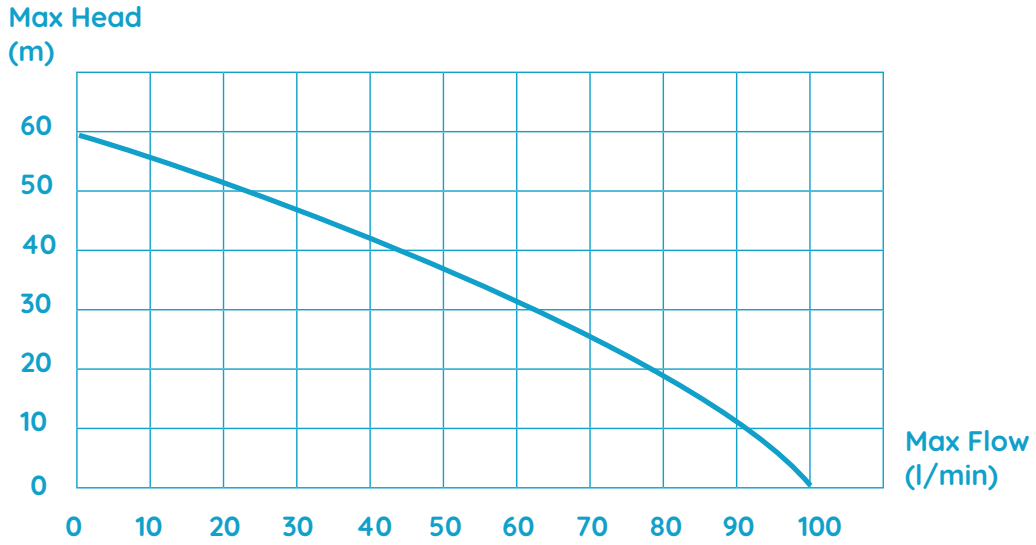

DIMENSIONS

INLET / OUTLET

1" BSPF

DIMENSIONS

Pump Only: 500 mm long, 220 High, 215mm wide

With controller: 450mm high

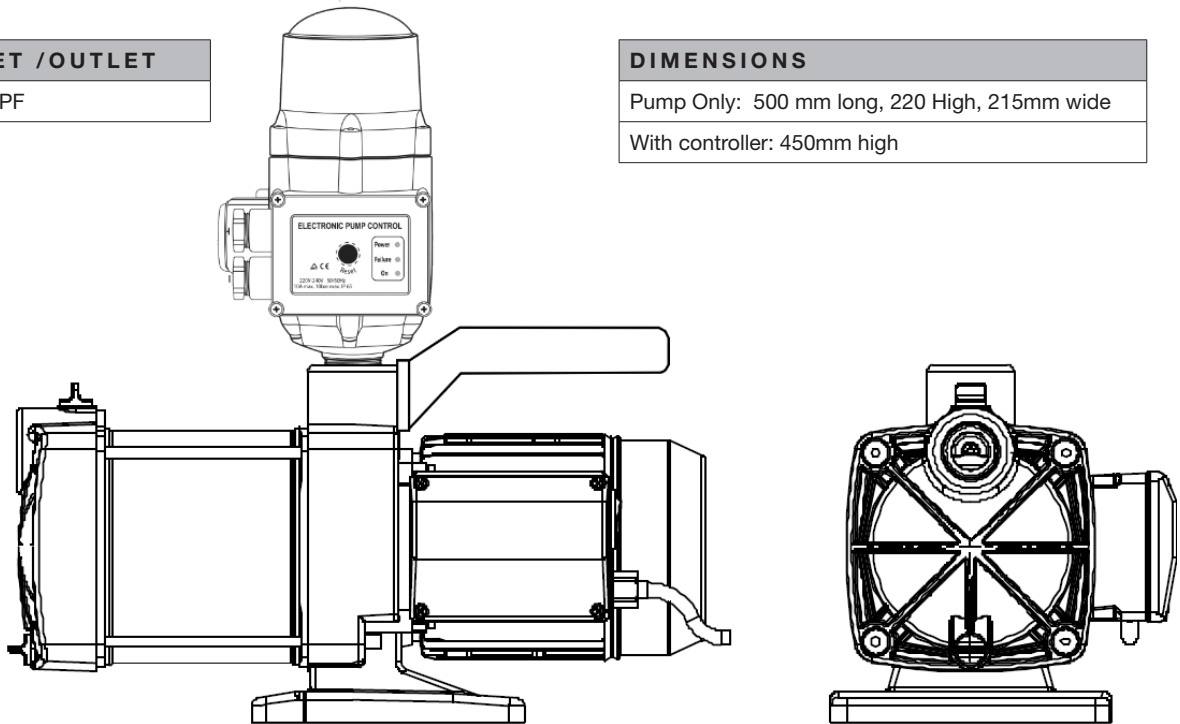

BASE FOOT

170 mm long, 275mm wide

WARRANTY / CERTIFICATIONS

